



JET Self-priming Jet Pump



Application

These pumps are suitable for pumping clean water and fluids which are not chemically aggressive to the pump components. They are extremely reliable, economical and simple to use, being particularly suitable for domestic applications such as the automatic distribution of water from small and medium-sized surge tanks, watering gardens, etc. These pumps should be installed in a covered area, protected against the weather. N.B. it is always advisable to install a foot valve or non-return valve on the suction opening.

Operating Condition

- Suction lift up to 9m
- Fluid temperature up to 60°C
- Maximum ambient temperature 40°C

Performance Range

- Flow rate up to 60L/min(3.6m³/h)
- Head up to 48m

Standard Data And Equipment

Single phase 220V/50Hz. Brass impeller, carbon steel motor shaft, with thermal protector inside. Other model and material such as three phase. 110V, 60Hz, dual voltage, stainless shaft, etc. will be available upon request.

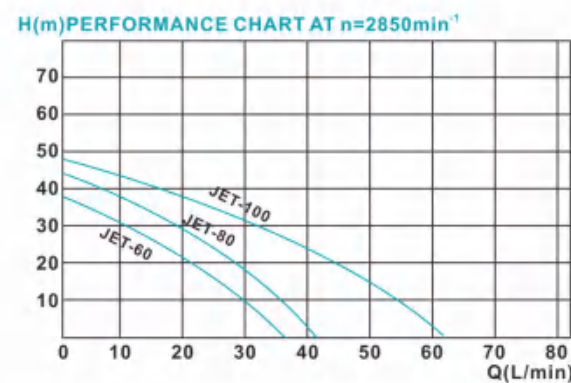

Technical Parameters

Model	Power		H. Max	Q. Max	Size	S. Head	Packing
	kW	HP	m	L/min	Inch	m	Qty
JET-60	0.37	0.5	38	35	1"x1"	9	1650
JET-80	0.55	0.75	44	40	1"x1"	9	1450
JET-100	0.75	1	48	60	1"x1"	9	1450

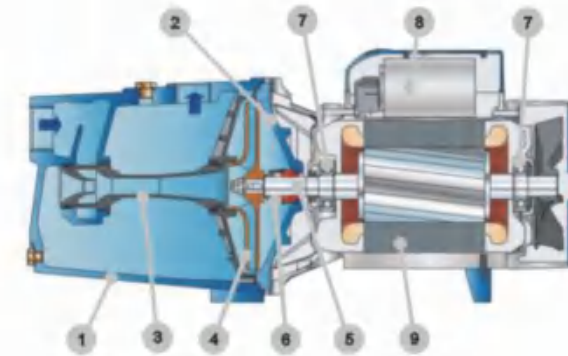

POS. COMPONENT	CONSTRUCTION CHARACTERISTICS
1 PUMP BODY	Cast iron, complete with threaded ports in compliance with ISO228/1
2 BODY BRACKPLATE	Cast Iron
3 NOZZLE ASSEMBLY	Noryl GFN2V
4 IMPELLER	Brass
5 MOTOR SHAFT	Stainless steel EN10088-3-1 4104
6 MECHANICAL SEAL	Seal Shaft Materials
	Model Diameter Stationary ring Rotational ring Elastomer
7 BEARINGS	AR-18 Ø18mm Graphite Ceramic NBR
	6203 ZZ/6203 ZZ
8 CAPACITOR	Pump Capacitance
	Single-phase (230V or 240V) (110V)
	JET-80M 16µF 450 VL 30µF 250 VL
9 ELECTRIC MOTOR	JET-100M 20µF 450 VL 40µF 250VL
	JETM: single-phase 230 V-50 Hz with thermal overload protector built-in to the winding.
	JET: three-phase 230/400V-50Hz
	Pumps fitted with the three-phase motor option offer IE2(IEC 60034-30)class high performance
	-Insulation: F class.
	-Protection: IP X4.

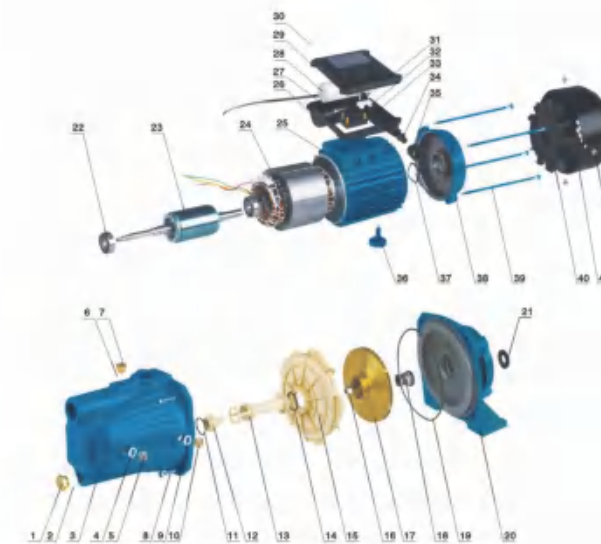

No.	Description	No.	Description
1	Drain plug	22	Pump side ball bearing
2	O-ring for drain plug	23	Shaft and rotor
3	Pump body	24	Stator
4	O-ring for gauge plug	25	Motor case
5	Gauge plug	26	Capacitor holding box
6	O-ring for filling plug	27	Washer for terminal board
7	Filling plug	28	Capacitor
8	Screw for pump body	29	Terminal cover
9	O-ring for switch plug	30	Screw for terminal box fixing
10	Switch plug	31	Screw for cable presser
11	O-ring for nozzle	32	Cable presser
12	Nozzle	33	Terminal board
13	Venturi tube	34	Outlet hole
14	O-ring for diffuser	35	Waterproof fairlead
15	Diffuser	36	Foot
16	Impeller nut	37	Adjusting ring
17	Impeller	38	Motor end cover
18	Mechanical seal	39	Motor tie-rod
19	O-ring for pump body	40	Fan
20	Motor front bracket	41	Fan cover
21	Splash guard	42	Screw for fan cover